



National
Defence

Défense
nationale

A-CR-CCP-911/PW-002



Canadian Cadet Organizations

Pipe Band – Snare Drum Reference Manual



Chapter 2

Snare Drum – Level Two

Chapter 2 – Table of Contents

	Tempo (BPM)	Page
Section 1 Technique Exercises		
Single Strokes	120	2-1-1
Double Strokes	96	2-1-2
Flams	90	2-1-3
Drags	68	2-1-4
Paradiddles	96	2-1-5
Quick March Attack Rolls	96	2-1-6
Slow March Attack Rolls	48	2-1-7
Section 2 Repertoire		
Mairi's Wedding	96	2-2-1
The Green Hills of Tyrol – Elementary	96	2-2-2
When the Battle's O'er – Elementary	96	2-2-3
Scotland the Brave – Elementary	96	2-2-4
The Blue Bells of Scotland	96	2-2-5
The Nut Brown Maiden	96	2-2-6
Will Ye No Come Back Again – Elementary	96	2-2-7
The Quaker's Wife – Elementary	96	2-2-8
The Steamboat	96	2-2-9
The Skye Boat Song – Elementary	48	2-2-10
Going Home – Elementary	48	2-2-11
Advance (Scotland the Brave) – Elementary	96	2-2-12
General Salute (The Maple Leaf Forever) – Elementary	96	2-2-12



C
H
A
P
T
E
R

2

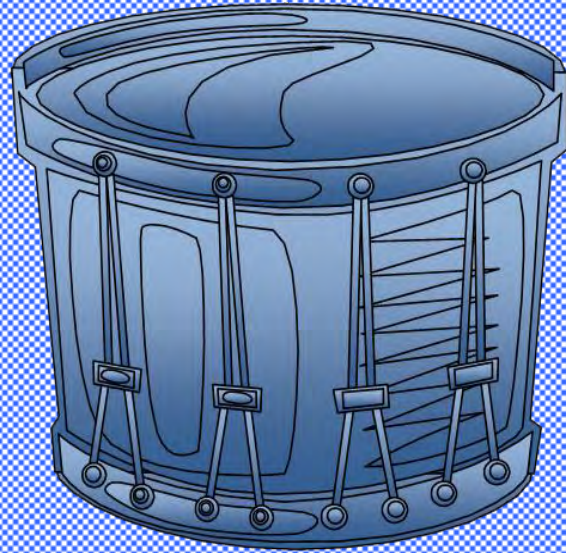

Section 1

Technique





Single Strokes

1 $\frac{2}{4}$ | :  :

2 $\frac{2}{4}$ | :  :

3 $\frac{2}{4}$ | :  :

4 $\frac{2}{4}$ | :  :

5 $\frac{2}{4}$ | :  :

6 $\frac{6}{8}$ | :  :

 2-1-1 

Double Strokes

7 $\frac{2}{4}$

8 $\frac{2}{4}$

9 $\frac{2}{4}$

10 $\frac{2}{4}$

11 $\frac{2}{4}$

12 $\frac{2}{4}$

13 $\frac{2}{4}$

2-1-2

Flams

14 $\frac{2}{4}$ 

15 $\frac{4}{4}$ 

16 $\frac{2}{4}$ 

17 $\frac{2}{4}$ 

18 $\frac{2}{4}$ 

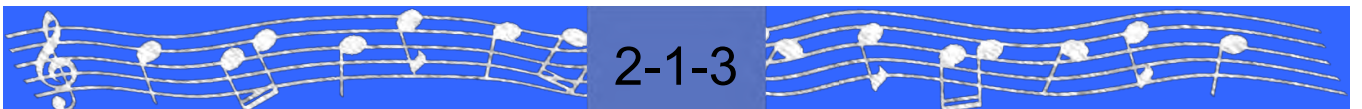
 2-1-3

Drags



- A drag is an embellishment similar to a flam.
- **Right Drag:** A buzz on the right hand followed by a main stroke on the left hand.
- **Left Drag:** A buzz on the left hand followed by a main stroke on the right hand.

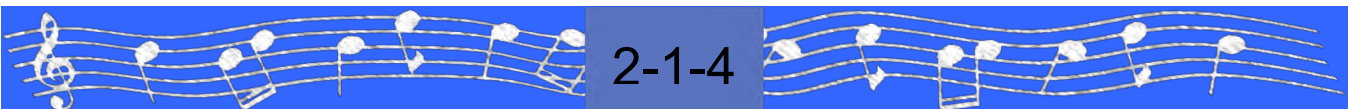

Paradiddles

21

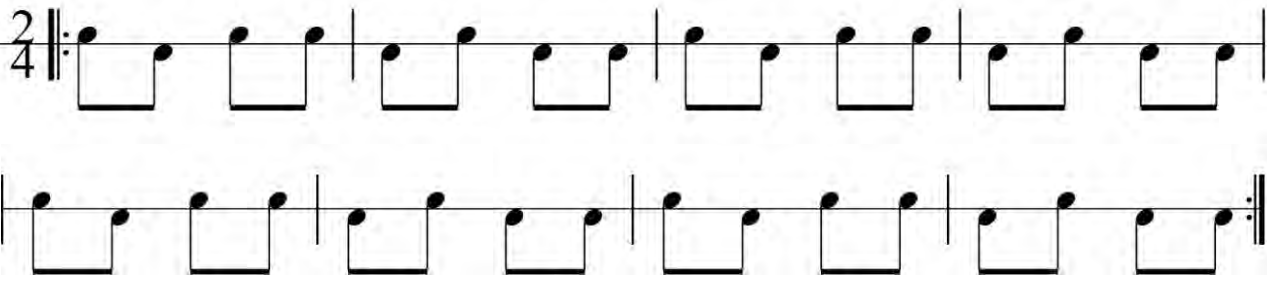

22

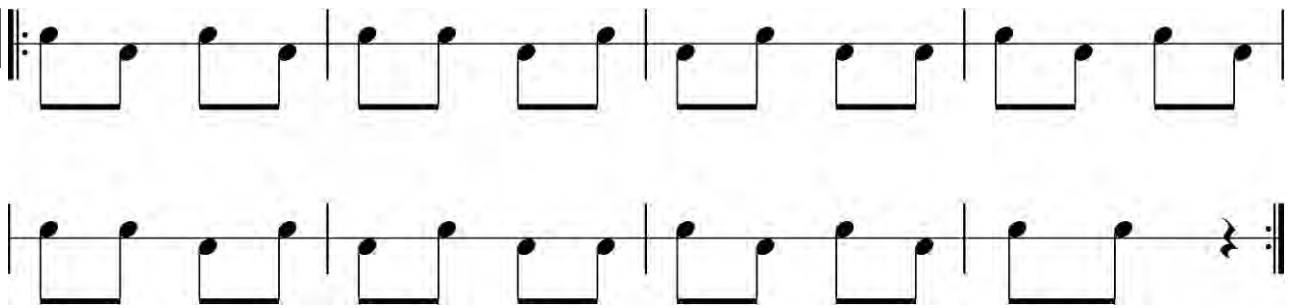

23

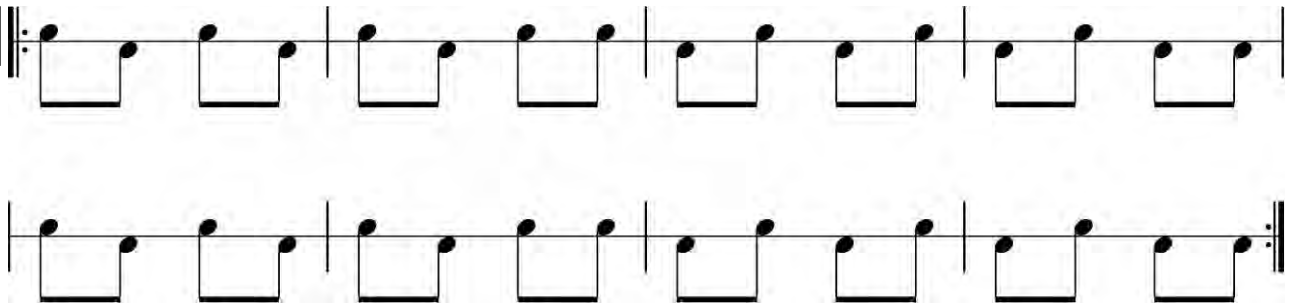

24

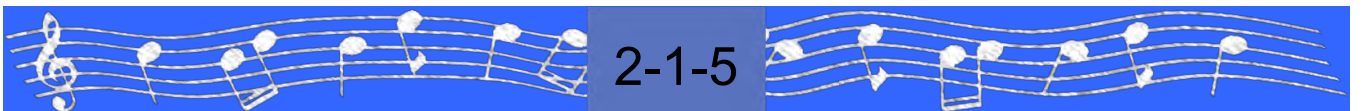

Attack Rolls

25 Quick March Attack

The musical score is divided into three sections: **Word of Command**, **Rolls**, and **Start of Tune**. The instruments are Tenor Drum, Bass Drum, Snare Drum, and Bagpipes, all in 4/4 time.

- Tenor Drum:** Plays a series of rhythmic strokes. In the 'Rolls' section, it features three 'roll' symbols (circles with an 'X').
- Bass Drum:** Plays a series of rhythmic strokes. In the 'Start of Tune' section, it has accents (>) and a 'V' mark.
- Snare Drum:** Plays a series of rhythmic strokes. In the 'Start of Tune' section, it has accents (>).
- Bagpipes:** Plays a series of rhythmic strokes. In the 'Start of Tune' section, it has accents (>). A note is marked with a 'V'.

Additional annotations include: "Rolls.....Quick March" under the Tenor Drum part in the first section; "Hand up to Bag" above the Bagpipes part in the 'Rolls' section; and "Drones.....'E'" below the Bagpipes part in the 'Start of Tune' section.



Attack Rolls

26 Slow March Attack

The musical score is divided into three sections: **Word of Command**, **Rolls**, and **Start of Tune**.

- Word of Command:** Tenor and Bass Drums play a rhythmic pattern of four strokes. The Snare Drum plays a similar pattern. The Bagpipes play a rhythmic pattern with the instruction "Hand up to Bag".
- Rolls:** Tenor and Bass Drums play a roll pattern of three strokes. The Snare Drum plays a roll pattern of three strokes. The Bagpipes play a roll pattern of three strokes with the instruction "Drones.....'E'".
- Start of Tune:** Tenor and Bass Drums play a rhythmic pattern of two strokes. The Snare Drum plays a rhythmic pattern of two strokes. The Bagpipes play a rhythmic pattern of two strokes.

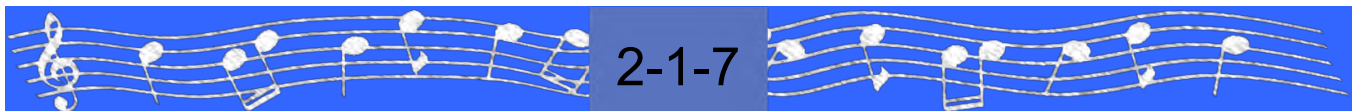

C
H
A
P
T
E
R

2

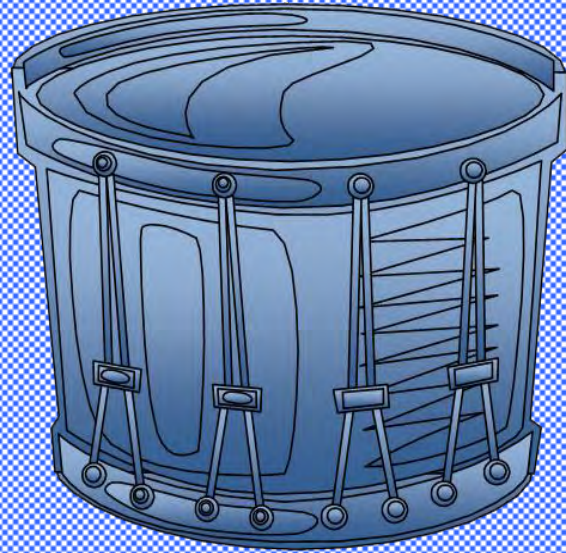

Section 2

Repertoire



Mairi's Wedding

March

The image displays a musical score for a march titled "Mairi's Wedding". The score is written in 2/4 time and consists of four staves. The first staff begins with a treble clef, a 2/4 time signature, and a key signature of one flat (B-flat). The melody is characterized by a steady eighth-note rhythm with various phrasing slurs and accents. The second and fourth staves conclude with double bar lines and repeat dots, indicating the end of the piece. The third staff continues the melodic line with similar phrasing.

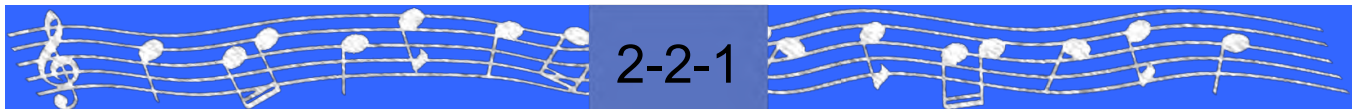

The Green Hills of Tyrol

Retreat March
Elementary

The musical score is written in treble clef with a 3/4 time signature. It consists of four staves of music. The first staff begins with a repeat sign. The melody features eighth and sixteenth notes, often beamed together. There are two triplet markings (indicated by a '3' above a bracket) in the second and third measures of the first staff, and the second and third measures of the second staff. The piece concludes with a repeat sign at the end of the fourth staff.

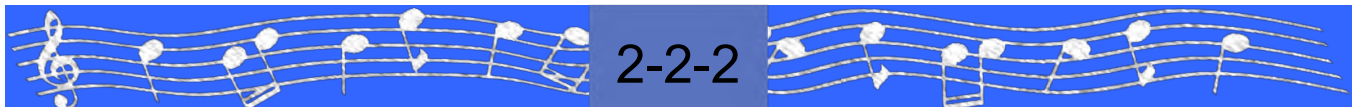

When The Battle's O'er

Retreat March
Elementary

The musical score is written on a single treble clef staff in 3/4 time. The key signature has one sharp (F#). The piece begins with a repeat sign. The melody consists of quarter and eighth notes, with several triplet markings (indicated by a '3' above a bracket) and repeat signs. The score is divided into four lines of music, each containing four measures. The first line starts with a repeat sign and ends with a repeat sign. The second line ends with a repeat sign. The third and fourth lines end with repeat signs.



Scotland The Brave

March
Elementary

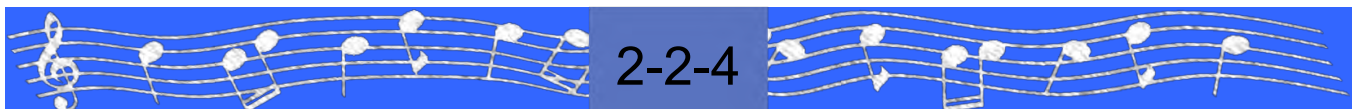

The Blue Bells of Scotland

March

The image shows the musical notation for the march 'The Blue Bells of Scotland'. It consists of two staves. The top staff begins with a treble clef, a 4/4 time signature, and a key signature of one sharp (F#). The melody is written in a simple, rhythmic style with eighth and quarter notes, and rests. The bottom staff provides a bass line accompaniment, primarily using chords and single notes. Both staves end with a double bar line and repeat dots.

A decorative footer at the bottom of the page features a blue background with white musical notation on a staff. The notation includes a treble clef, a key signature of one sharp, and several notes. In the center of this footer is a grey rectangular box containing the text '2-2-5' in white.

The Nut Brown Maiden

March

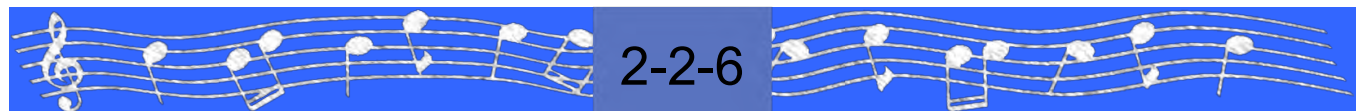

Will Ye No Come Back Again

March
Elementary

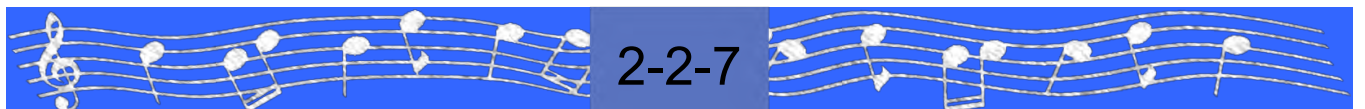

The Quaker's Wife

March
Elementary

Musical score for 'The Quaker's Wife' in 8/8 time. The score consists of four staves. The first staff begins with a treble clef and a key signature of one flat. The music features a variety of note values, including quarter, eighth, and sixteenth notes, as well as rests. Phrasing is indicated by slurs and ties. A triplet of eighth notes is marked with a '3' in the second and fourth staves. The piece concludes with a double bar line and repeat dots.

Decorative footer featuring a blue background with white musical notation on a staff. The notation includes a treble clef, a series of eighth notes, and a central grey box containing the text "2-2-8".

The Steamboat

March

The musical score for 'The Steamboat' is written in 2/4 time and consists of 16 measures. It begins with a treble clef, a key signature of one flat (B-flat), and a repeat sign. The melody is characterized by a steady eighth-note rhythm with frequent beamed eighth notes. The score is divided into two 8-measure phrases, each ending with a double bar line and repeat dots. The first phrase contains measures 1 through 8, and the second phrase contains measures 9 through 16.

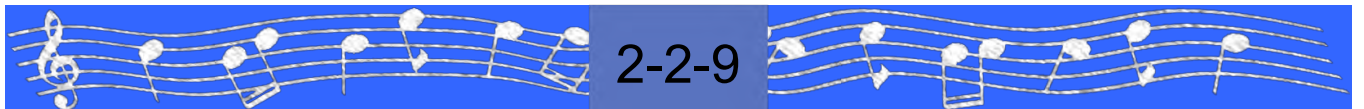

The Skye Boat Song

Slow March
Elementary

The musical score for 'The Skye Boat Song' is presented in four staves. The first staff begins with a treble clef, a 6/8 time signature, and a key signature of one flat (B-flat). The melody is written in a simple, accessible style suitable for elementary students. It features a series of eighth notes and quarter notes, with several measures containing beamed eighth notes. The piece concludes with a double bar line and repeat dots. The second and fourth staves also end with double bar lines and repeat dots, indicating the end of the piece.

A decorative footer at the bottom of the page features a blue background with white musical notation on a staff. The notation includes a treble clef, a key signature of one flat, and several notes. In the center of the footer, the page number '2-2-10' is displayed in white text on a dark blue rectangular background.

Going Home

Slow March
Elementary

Musical score for 'Going Home', a Slow March in 8/8 time, Elementary level. The score is written in treble clef and consists of four staves. The first staff begins with a treble clef, a key signature of one flat (B-flat), and a time signature of 8/8. The music features a melody of eighth and quarter notes with slurs, and a bass line of chords and eighth notes. The second staff continues the melody and bass line. The third staff includes two slurs under the bass line. The fourth staff concludes the piece with a double bar line and repeat dots.

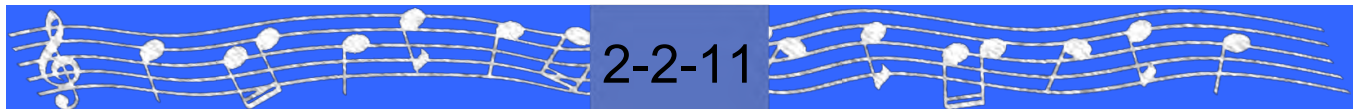

The Advance and General Salute

Advance

Scotland The Brave

Arr: Maj A.M. Cairns MMM CD

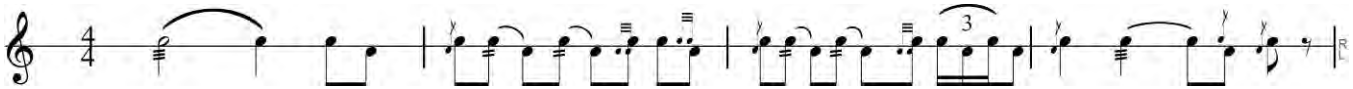

General Salute

The Maple Leaf Forever

Arr: Maj A.M. Cairns MMM CD

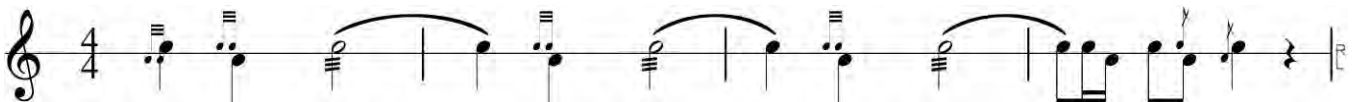

There are three salutes used within the Canadian Forces and Canadian Cadet Organizations: the Royal Salute*, the Royal (Vice-Regal) Salute** and the General Salute. The following table illustrates the use of these salutes based on the status of the dignitary being honoured.

*Note: The Royal Salute is covered in Level 4. **Note: The Royal (Vice-Regal) Salute is covered in Level 3.

Royal Salute (Mallorca)

- HM the Queen
- Members of the Royal Family
- Foreign Sovereigns
- Members of Reigning Foreign Families
- Heads of State
- Governor Generals of Commonwealth Countries

Royal (Vice-Regal) Salute (Mallorca / O' Canada)

- Governor General of Canada
- Lieutenant Governor of a Canadian Province

General Salute (Maple Leaf Forever)

- Prime Minister of Canada
- Premiers of Canadian Provinces
- Members of Parliament (provincial or federal)
- Municipal Politicians
- Military Officers (major and above)
- Distinguished Persons

